

Transmitter Functions Reference Guide

LOCK: Press and release the "LOCK" button.



• THE DOORS WILL LOCK

TRUNK RELEASE: Press and release the "TRUNK" button

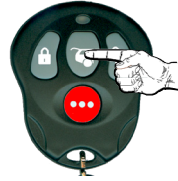

• THE TRUNK WILL OPEN (IF CONNECTED)

UNLOCK: Press and release the "UNLOCK" button.

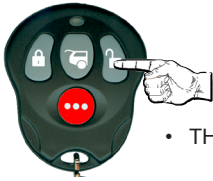

• THE DOORS WILL UNLOCK

ACTIVATE 3RD CHANNEL: Press and release the "..." button



• THERE IS NO VISUAL OR AUDIBLE INDICATION. IF CONNECTED TO AN OPTIONAL ACCESSORY, IT MAY PROVIDE CONFIRMATION.

About The REC-43 Module Operation

The REC-43 is a "stand-alone" universal receiver unit for 12 Volt applications. It has 4 outputs, which can be assigned to any of the transmitter's buttons. When the REC-43 receives a signal from the included transmitter, it activates the pre-assigned output. When activated the outputs supply 500mA (-) negative ground (500 milliamps = 0.5amp of ground). Each of the outputs may be configured as:

- a) "TIMED PULSE" = When the output is activated, it will last for a preset period of time, from @ 1/5 of a second to @ 30 seconds.
- b) "ON DEMAND" = When the output is activated, it will last for as long as the transmitter's button is pressed.
- c) "LATCH / UNLATCH" = When the output is activated, it will remain activated until an additional signal is received from the transmitter.

SEE THE INSTRUCTIONS ON THE OTHER SIDE OF THIS PAGE FOR CONFIGURING THE OUTPUTS

Wiring Overview

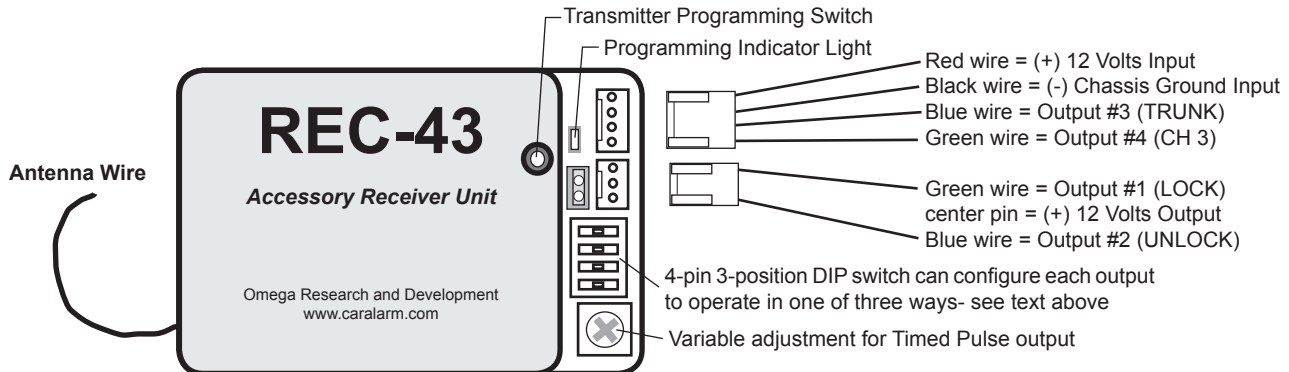

Red wire: (+) 12 Volts Input, on the 4-pin plug supplies power to operate the REC-43.

Black wire: Negative Ground, must be connected to the negative side of the power source like a vehicle's chassis.

The Outputs: are numbered as #1, #2, #3, and #4 in reference to their sequence within the transmitter programming procedure (see "Programming Transmitters" and "Configuring Outputs"). Specific connection of these wires is contingent upon the application. When the REC-43 is used to operate other controlling devices (remote engine starter, for example), connection is typically wire-to-wire directly to the device's activation wire. The other most common interface method is connecting the output wire to activate a relay to control the vehicle's circuit (an example would be locking or unlocking the doors). All 4 outputs have a 500mA capacity that should not be exceeded.

Note: The center pin on the 3-pin plug is (+) 12 Volts Output (500mA). It provides power to relay coils only of an optional door lock/unlock interface.

PROGRAMMING TRANSMITTERS:

The REC-43 needs to be connected to power and ground, and all of the transmitters which are to operate the unit need to be present. A small instrument, such as screwdriver or toothpick, is needed to press the Transmitter Programming Switch which is located below the small opening on the top of REC-43's case.

Your Action:	Unit's Reaction:
STEP 1: Press and hold the Transmitter Programming Switch for 2 seconds.	The Transmitter Programming Indicator Light will illuminate, and the REC-43 will softly chirp 4 times, then chirp louder one more time. It is ready to receive the first transmitter's button codes.
STEP 2: Release the Transmitter Programming Switch.	
STEP 3: In sequence of desired operation, press the buttons on the first transmitter. Only one button, or up to four buttons, on each transmitter may be coded into the REC-43.	The unit will beep once and the indicator light will flash once when the first button code is learned, then 2 times for the second button code, 3 times for the third button and 4 times for the fourth button. The REC-43 has four button code "slots" for each transmitter, the code slots' numerical order in the programming procedure equals the output number- slot #1 is output #1, slot #2 is output #2, slot #3 is output #3, and slot #4 is output #4.
STEP 4: To program the button codes of an additional transmitter, press and hold the Transmitter Programming Switch.	The REC-43 will chirp twice to indicate that it's ready to learn the second transmitter's button codes (or chirp 3 times for a third transmitter, or four times for a fourth transmitter).
REPEAT Step 2 and Step 3.	
<p>TRANSMITTER PROGRAMMING NOTE #1: Exit transmitter programming mode by waiting 10 seconds, without transmitting any button codes. Upon exiting, the unit chirps 5 times and the LED goes out.</p> <p>TRANSMITTER PROGRAMMING NOTE #2: a transmitter code must be entered into a slot in order to access the next slot, even if the first output(s) are not planned to be used.</p>	

CONFIGURING THE OUTPUTS:

Each output can operate as a Timed Pulse, On Demand, or Latch / Unlatch type. The way in which the operation is determined is by a 3-position switch; each output has its own switch, as shown below.

On Demand and Latch / Unlatch programming:
To configure On Demand or Latch / Unlatch operation, simply place the selected output's switch in the center or outboard position.

Timed Pulse programming:
Placing an output's switch in the inboard position will configure the output for Timed pulse operation. The length of time of the output is adjustable from 1/10 second to 30 seconds. To change an output's pulse time, remove the programming jumper, then operate the output and adjust the output pulse more or less by turning the variable adjustment. When the desired output pulse time has been properly set, reinstall the programming jumper.

